

## RUDDER - MAINTENANCE PRACTICES

### 1. General

- A. Rudder maintenance practices consist of rudder pedals, pulleys and cables removal/installation, and rigging rudder system.

### 2. Rudder Pedals, Pulleys, and Cables Removal/Installation

- A. Remove Rudder Pedals, Pulleys, and Cables (Refer to Figure 201).

- (1) Remove carpet or vinyl cover, plywood floor covers (118), floorboard access covers, tailcone upholstery panel, and tailcone stinger to gain access to system.
- (2) Remove cotter pins (75), nuts (74), washers (73), and bolts (72) from clevis ends of cables (70) and (71). Detach cables from cable arms (49).
- (3) Remove nuts (23) and (23A), washers (22) and (22A), bolts (21) and (21A), bearing (36), bushing (36A), washers (37), safety wire (35), and roll pin (25). Detach steering pushrod (20) from link (34), and flex shaft (26) from coupler (24).
- (4) Remove nuts (12), washers (11), bolts (10), cotter pins (8), spacers (7), and pins (6). Detach pedals (1), pedal arm assemblies (9), and links (5) from link assemblies (42) and forward and aft torque tubes (58) and (59).
- (5) Remove the master cylinder. Refer to Chapter 32, Master Cylinder - Maintenance Practices.
- (6) Remove cotter pins (19), washers (18), and pins (16) and (17). Detach left and right brake cylinders (14) and (15) from pedals (2) and bearings (54).
- (7) Remove nuts (57), washers (56), and bolts (55) from bearings (54) and spacers (38). Detach remaining rudder controls from floorboard of airplane and place on bench.
- (8) Remove cotter pins (8), spacer (7), and pins (6). Detach links (13) from pedals (2) and link assemblies (42) and (61).
- (9) Remove roll pins (4) and pins (3). Disconnect rudder pedals (2) from forward and aft torque tubes (58) and (59).
- (10) Remove nuts (45), washers (44), and bolts (43). Detach link assemblies (42) and (61) from forward and aft brake interconnect tubes (40) and (41).
- (11) For airplanes 208B5000 and On remove the brake return springs. Refer to Chapter 32, Brake Return Spring - Removal/Installation.
- (12) Remove forward and aft interconnect tubes from forward and aft torque tubes (58) and (59).
- (13) Remove nuts (80), washers (79), and bolts (78). Detach pulleys (76) and spacers (77) from supports (81).
- (14) Remove nuts (85), washers (84), and bolts (83). Detach pulleys (82) from supports (86).
- (15) Airplanes 20800001 Thru 20800185 and 208B0001 Thru 208B0214 except airplanes incorporating SK208- 76, remove nuts (94), washers (93), and bolts (92). Detach fairleads (90) from supports (91).
- (16) Remove bolts (97) and washers (98). Detach pulleys (95) from supports (96).
- (17) Remove nuts (103), washers (102), and bolts (101). Detach pulleys (100) from supports (104).
- (18) Remove safety wire or clips and disconnect turnbuckles (106) and (116) cables (71), (107), (70), and (108).
- (19) Remove nuts (112), washers (111), spacers (110), and bolts (109).
- (20) Remove cables (70), (71), (107), and (108) from system.

**NOTE:** To ease replacement of cables, attach a length of wire to cable to be removed from system. After removing cable, leave wire in place, routed through structure. When replacing cable, attach it to wire and pull cable into position with wire.

- B. Rudder Pedals, Pulleys, and Cables Installation (Refer to Figure 201).

**NOTE:** Before assembling rudders, check condition of bushings in each end of forward and aft torque tubes (58) and (59). If bushings are scored or excessively worn, they should be replaced.

- (1) Install forward and aft brake interconnect tubes (40) and (41) in forward and aft torque tubes (58) and (59).
- (2) Attach link assemblies (42) and (61) to forward and aft brake interconnect tubes (40) and (41). Replace bolts (43), washers (44), and nuts (45).

**NOTE:** Forward and aft torque tubes (58) and (59) must be rigged before installing rudder controls in airplane.

- (3) Rig torque tubes as noted:
  - (a) Align 0.093 inch diameter holes in rigging arms (50) and install 3/32 x 3/4 inch cotter pin (51).
  - (b) Keep the bearings as matched sets and clean both upper and lower bearings (52) and (54) halves with a Type I, Class I solvent applied to a soft cloth. Refer to Chapter 20, General Solvents/Cleaners - Maintenance Practices.
  - (c) For Airplanes 20800001 and On and 208B0001 thru 208B4999, apply MIL-L-7870 or equivalent grease to the bearing surfaces.
  - (d) For Airplanes 208B5000 and On, apply MIL-PRF-23827 or equivalent grease to the bearing surfaces.
  - (e) Place lower halves of bearings (52) and (54) on a flat surface. Install forward and aft torque tubes (58) and (59) in bearings (52) and (54).
  - (f) Check that gear teeth (60) are engaged and tape forward (58) and aft (59) torque tubes securely adjacent to teeth (60).
- (4) Attach links (13) to link assemblies (42) and (61). Replace pins (6), spacers (7), and cotter pins (8).
- (5) Attach pedals (2) to forward and aft torque tubes (58) and (59) and links (13). Replace pins (3), roll pins (4), pins (6) and cotter pins (8).
- (6) Attach upper halves to lower halves of bearings (52) and (54).

**NOTE:** To facilitate installation of rudder control in airplane, install one bolt (55) in each bearing (52) and (54) and hand-tighten nut (57). Move partially assembled rudder control from bench and install in airplane.
- (7) Remove hand-tightened nuts and install remaining bolts (55) and spacers (38) to attaching holes in floorboard.
  - (a) For Airplanes 208B5000 and On, clean the grease Zerk fittings and lubricate through the fittings until lubricant is visible.
- (8) With a clean cloth, wipe off any access grease around bearings (52) and (54).
- (9) Replace washers (56) and nuts (57). Remove tape from forward and aft torque tubes (58) and (59), and cotter pin (51) from rigging arms (50).
- (10) Attach pedals (1), pedal arm assemblies (9), and links (5) to forward and aft torque tubes (58) and (59). Replace bolts (10), washers (11), and nuts (12).
- (11) Attach links (5) to link assemblies (42). Replace pins (6) and cotter pins (8).
- (12) Connect right and left brake cylinders (14) and (15) to pedals (2) and bearings (54). Replace pins (16) and (17), washers (18), and cotter pins (19).
- (13) Install the master cylinders. Refer to Chapter 32, Master Cylinder - Maintenance Practices.
- (14) Add brake fluid and bleed system. Refer to Chapter 32 for brake system maintenance.
- (15) Replace cables (70), (71), (107), and (108) in system.
- (16) Attach clevis ends of cables (107) and (108) to rudder bellcrank (105). Replace bolts (109), bushings (110), washers (111), and nuts (112).
- (17) Attach pulleys (100) and cables (70) and (71), to supports (104). Replace bolts (101), washers (102), and nuts (103).
- (18) Airplanes 20800001 Thru 20800185 and 208B0001 Thru 208B0214 except airplanes incorporating SK208-76, attach fairleads (90) to supports (91); replace bolts (92), washers (93), and nuts (94).
- (19) Attach pulleys (95) and cables (70) and (71), to supports (96). Replace bolts (97) and washers (98).
- (20) Attach pulleys (82) and cables (70) and (71), to supports (86). Replace bolts (83), washers (84), and nuts (85).
- (21) Attach pulleys (76) and cables (70) and (71), to supports (81). Replace bolt (78), spacer (77), washer (79), and nut (80).
- (22) Attach clevis ends of cables (70) and (71) to cable arms (49). Replace bolts (72), washers (73), nuts (74), and cotter pins (75).
- (23) Attach cables (71) and (107) to turnbuckle (106). Attach cables (70) and (108) to turnbuckle (116).
- (24) Tighten turnbuckles (106) and (116) evenly; set cable tension at 25 to 35 pounds. Safety wire or install clips on turnbuckles.
- (25) Check that threads in shaft (39) are centered in link (34) and nut (39A).

- (26) Attach flex shaft (26) to coupler (24). Align attaching holes and replace roll pin (25) and safety wire.
- (27) Connect steering pushrod (20) to link (34). Replace bearing (36), bushings (36A), bolts (21) and (21A), washers (22), (22A), (37), and nuts (23) and (23A).

**NOTE:** Make sure the rudder trim system is correctly rigged.

- (28) For airplanes 208B5000 and On, install the brake return springs. Refer to Chapter 32, Brake Return Spring - Removal/Installation.

**WARNING:** Be sure rudder moves in correct direction when rudder pedals are actuated. Check for crossed or wrapped cables.

- (29) Replace carpet or vinyl cover, floorboard access covers, plywood floor covers (118), tailcone upholstery panel, and tailcone stinger.

### 3. Rudder System Rigging

- A. Rig Rudder System (Refer to Figure 201).

**NOTE:** All control surface cable tensions should be rigged at an ambient temperature of 70°F. Allow temperature to stabilize for a period of four hours before setting cable tensions.

- (1) Remove carpet or vinyl floor cover, plywood floor covers (118), floorboard access covers, upholstery panel at tailcone entrance, and tailcone stinger to gain access to system.
- (2) Remove nut (23), washer (22), and bolt (21). Detach pushrod (20) from link (24). Move pushrod away from path of link.
- (3) Remove safety wire and roll pin (25). Disconnect flex shaft (26) from coupler (24).
- (4) Remove safety wire or clips and loosen turnbuckles (106) and (116).

**NOTE:** Hold rudder rigging protractor against vertical stabilizer with dial adjacent to trailing edge of rudder 1.56 inches (39.62 mm) above rudder skin trim (measure along fin skin trim) with aft end at lower end of rudder trailing edge.

- (5) Clamp a block across face of rudder pedals (1) and (2).
- (6) Adjust turnbuckles (106) and (116) to place trailing edge in line with zero mark on rudder travel protractor. Set cable tension at 25 to 35 pounds; safety wire or install clips on turnbuckles.
- (7) Remove block from rudder pedals (1) and (2).
- (8) Loosen locknuts (115) and set left and right stop bolts (113) and (114) to allow maximum rudder travel in either direction of 23 to 27 degrees on landplanes regardless of which rudder is installed. Tighten locknuts (115).

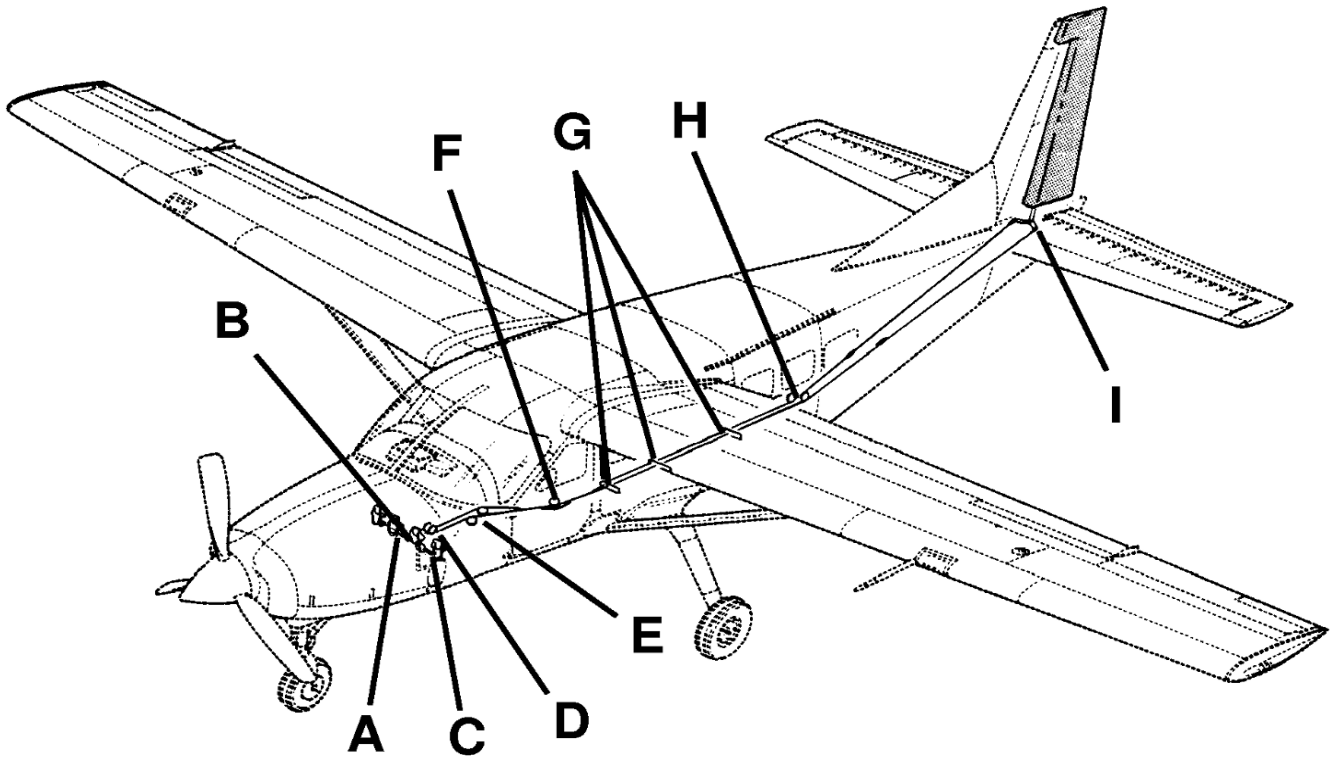
**NOTE:** Amphibian or floatplanes equipped with Wipline Model 8000 floats and floatplane rudder: set rudder travel at 23 to 25 degrees left and right.

- (9) Remove rudder rigging protractor from vertical stabilizer.
- (10) Check that threads on shaft (39) are centered in link (34) and nut (39A). Adjust if required.
- (11) With rudder streamlined, install flex shaft (26) on coupler (24) and align attaching holes. Replace roll pin (25) and safety wire.
- (12) Attach steering pushrod (20) to link (34). Replace bolt (21), washer (22), and nut (23).
- (13) Replace tailcone stinger, tailcone upholstery panel, floorboard access covers, plywood floor covers (118), and carpet or vinyl floor cover.

**NOTE:** If pointer (28) fails to center when rudder is streamlined, loosen screw (29) until pointer (28) can be moved to neutral position. Tighten screw after setting pointer.

Figure 201 : Sheet 1 : Rudder System Installation

A22538



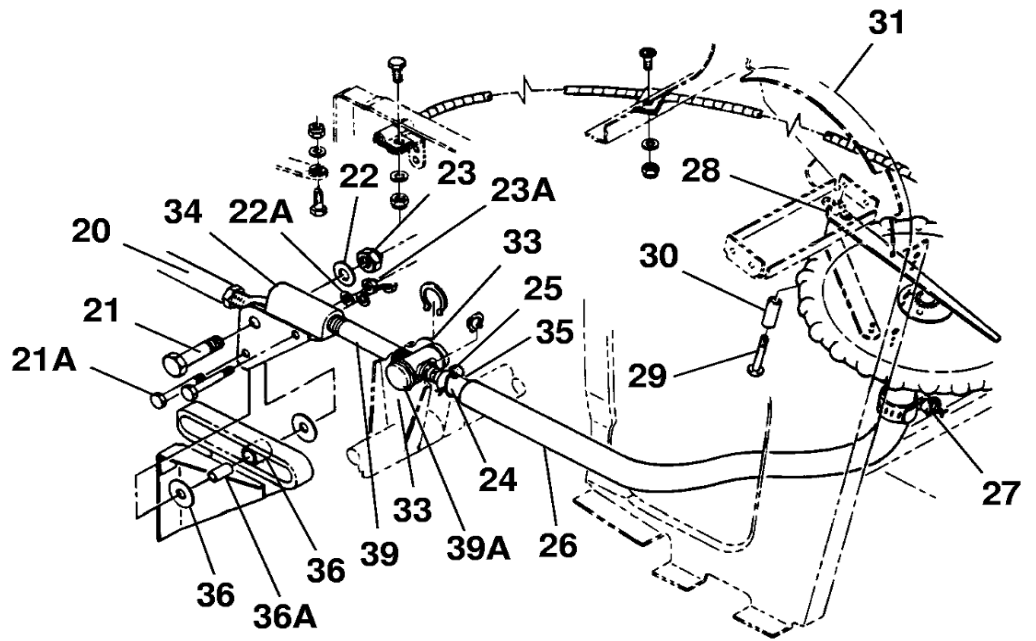
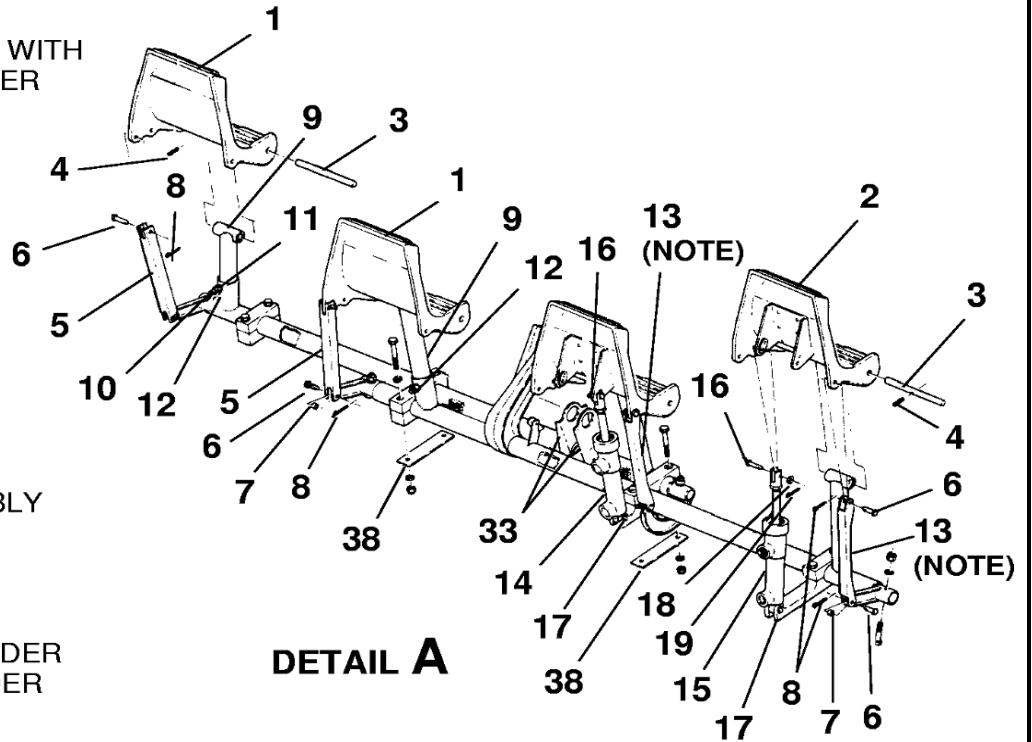
2662X1002

Figure 201 : Sheet 2 : Rudder System Installation

A22539

**NOTE:** INSTALL LINKS (13) WITH  
 1.75 INCH SLOT OVER  
 PEDAL TAB.

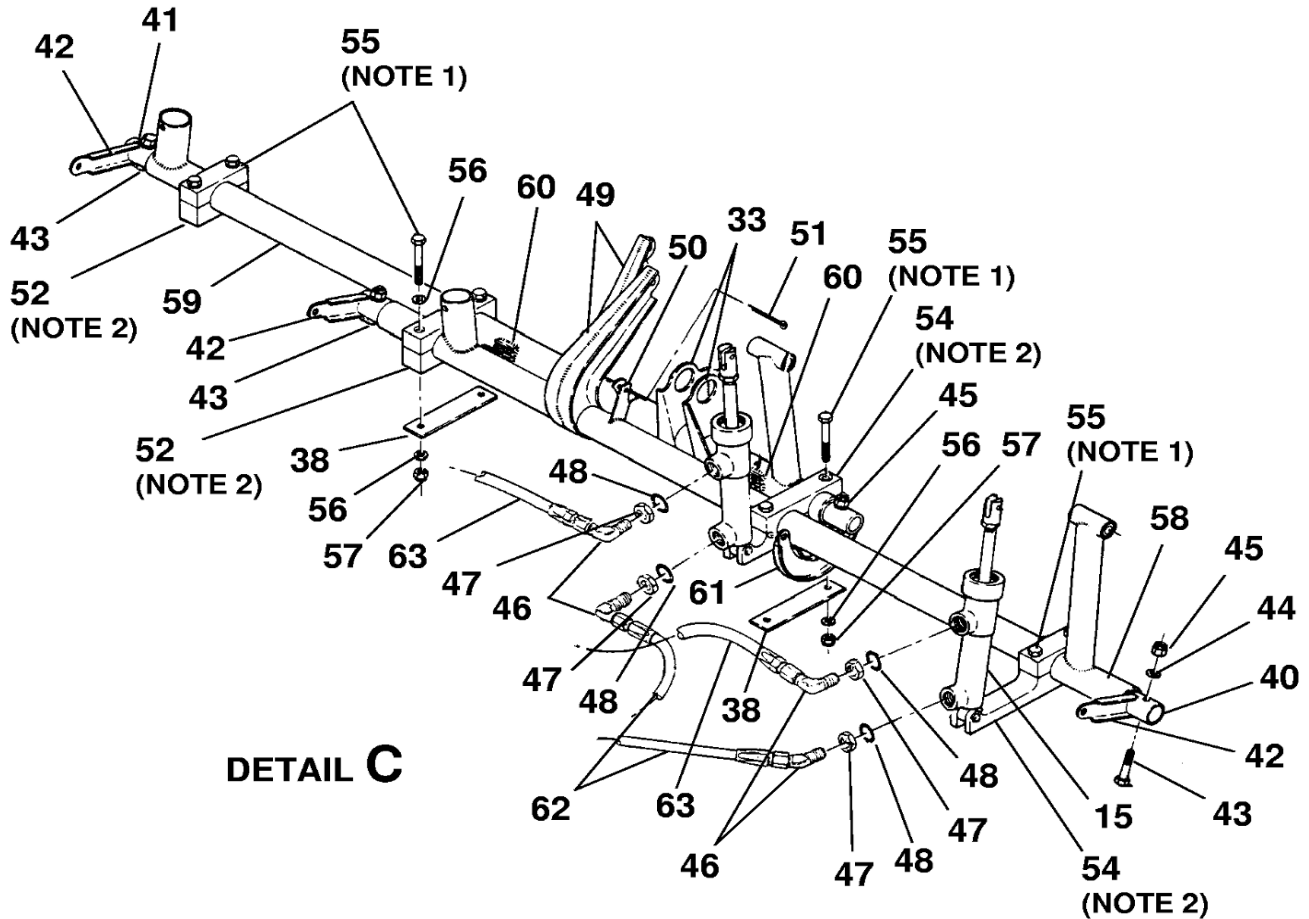
1. COPILOT PEDAL
2. PILOT PEDAL
3. PIN
4. ROLL PIN
5. LINK
6. PIN
7. SPACER
8. COTTER PIN
9. PEDAL ARM ASSEMBLY
10. BOLT
11. WASHER
12. NUT
13. LINK (NOTE)
14. RIGHT BRAKE CYLINDER
15. LEFT BRAKE CYLINDER
16. PIN
17. PIN
18. WASHER
19. COTTER PIN
20. STEERING PUSHROD
21. BOLT
- 21A. BOLT
22. WASHER
- 22A. WASHER
23. NUT
- 23A. NUT
24. COUPLER
25. ROLL PIN
26. FLEX SHAFT
27. CLAMP
28. POINTER
29. SCREW
30. SPACER
31. PEDESTAL
32. TRIM WHEEL
33. STEERING ARM
34. LINK
35. SAFETY-WIRE
36. BEARING
- 36A. BUSHING
37. WASHER
38. SPACER
39. SHAFT
- 39A. NUT



A2662X1003  
 B2662X1004

Figure 201 : Sheet 3 : Rudder System Installation

A22540



**NOTE 1:** INSTALL BOLTS (55) IN AIRPLANE WITH HEADS UP.

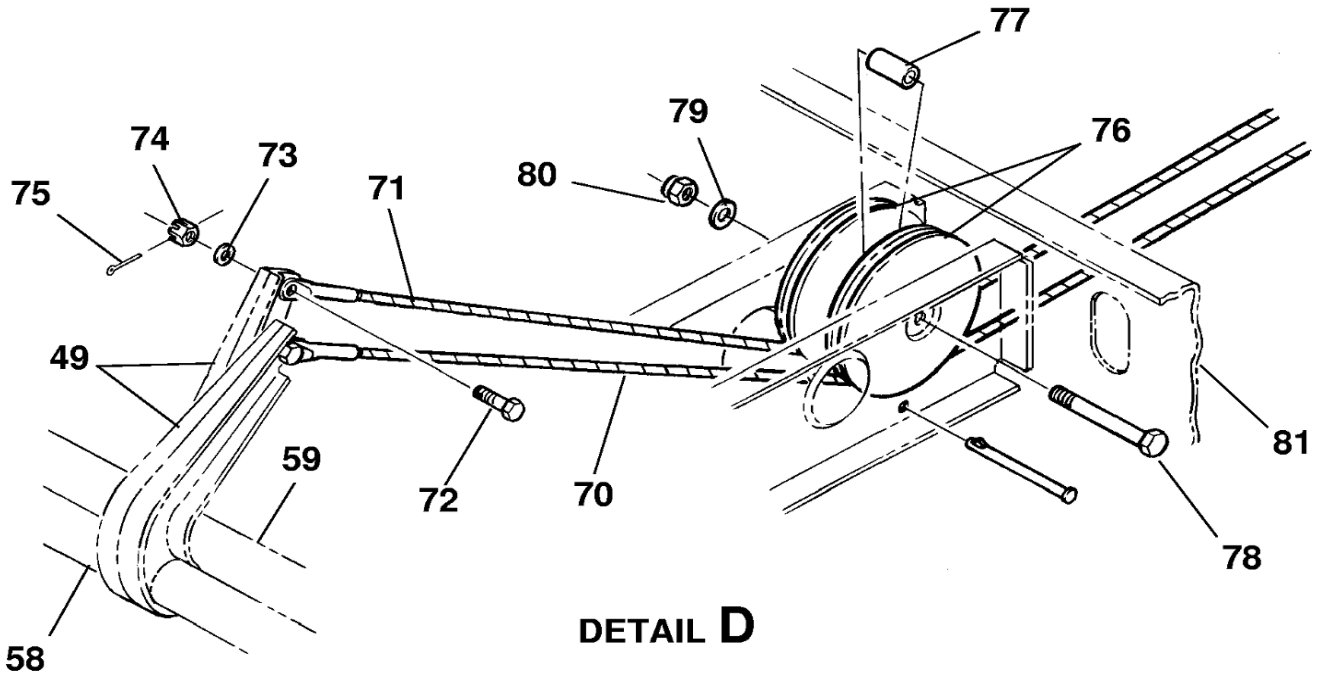
**NOTE 2:** KEEP BEARINGS (52) AND (54) IN MATCHED SETS.

- |     |                                 |     |   |
|-----|---------------------------------|-----|---|
| 14. | RIGHT BRAKE CYLINDER            | 51. | COTTER PIN                                |
| 15. | LEFT BRAKE CYLINDER             | 52. | BEARING                                   |
| 33. | STEERING ARM                    | 53. | SPACER                                    |
| 38. | SPACER                          | 54. | BEARING                                   |
| 40. | FORWARD BRAKE INTERCONNECT TUBE | 55. | BOLT                                      |
| 41. | AFT BRAKE INTERCONNECT TUBE     | 56. | WASHER                                    |
| 42. | LINK ASSEMBLY                   | 57. | NUT                                       |
| 43. | BOLT                            | 58. | FORWARD TORQUE TUBE                       |
| 44. | WASHER                          | 59. | AFT TORQUE TUBE                           |
| 45. | NUT                             | 60. | GEAR TEETH                                |
| 46. | FITTING                         | 61. | LINK ASSEMBLY                             |
| 47. | NUT                             | 62. | LOWER LEFT AND RIGHT BRAKE CYLINDER HOSES |
| 48. | O-RING                          | 63. | UPPER LEFT AND RIGHT BRAKE CYLINDER HOSES |
| 49. | CABLE ARM                       |     |   |
| 50. | RIGGING ARM                     |     |   |

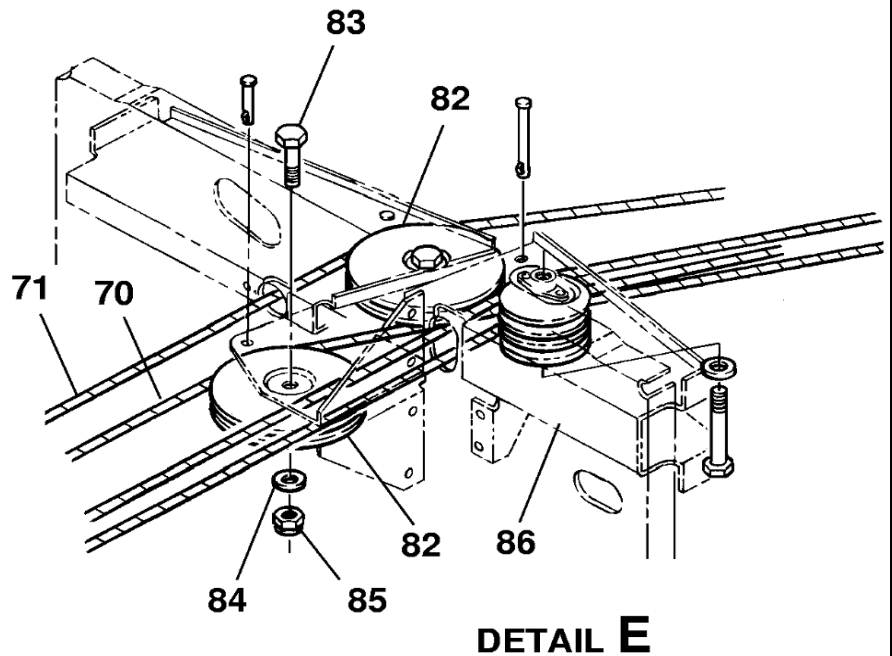
C2662X1005

Figure 201 : Sheet 4 : Rudder System Installation

A22542



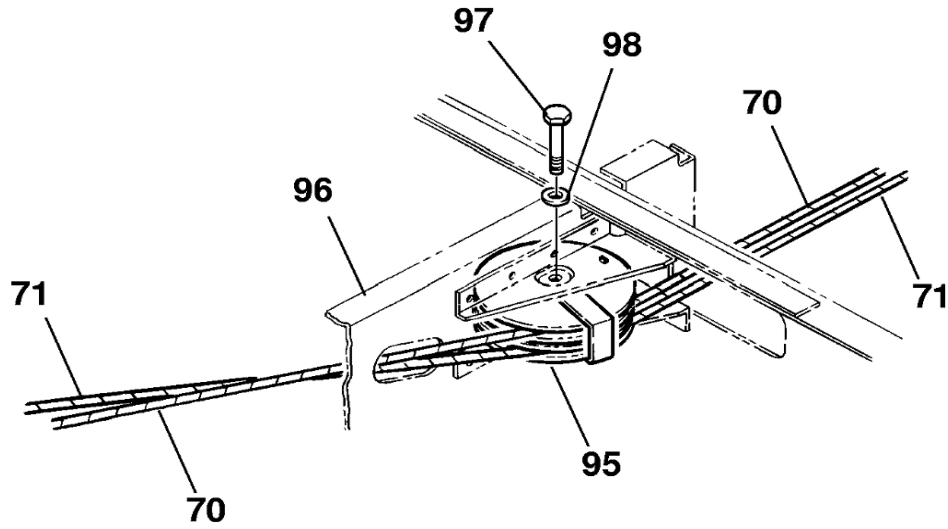
- 49. CABLE ARM
- 58. FORWARD TORQUE TUBE
- 59. AFT TORQUE TUBE
- 70. LEFT CABLE
- 71. RIGHT CABLE
- 72. BOLT
- 73. WASHER
- 74. NUT
- 75. COTTER PIN
- 76. PULLEY
- 77. SPACER
- 78. BOLT
- 79. WASHER
- 80. NUT
- 81. SUPPORT
- 82. PULLEY
- 83. BOLT
- 84. WASHER
- 85. NUT
- 86. SUPPORT



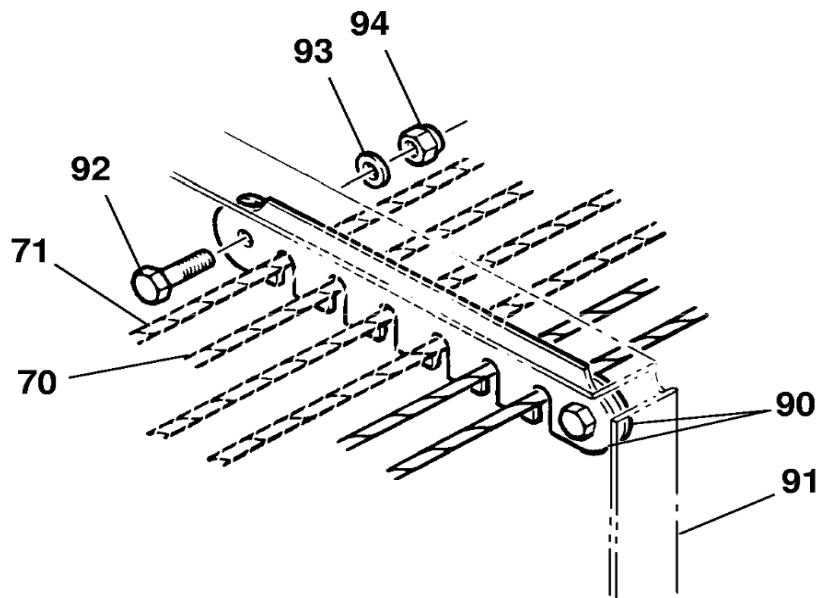
D26622002  
 E26622001

Figure 201 : Sheet 5 : Rudder System Installation

A22543



**DETAIL F**



**DETAIL G**

AIRPLANES 20800001 THRU 20800185  
 AND 208B0001 THRU 208B0214  
 EXCEPT AIRPLANES INCORPORATING  
 SK208-76

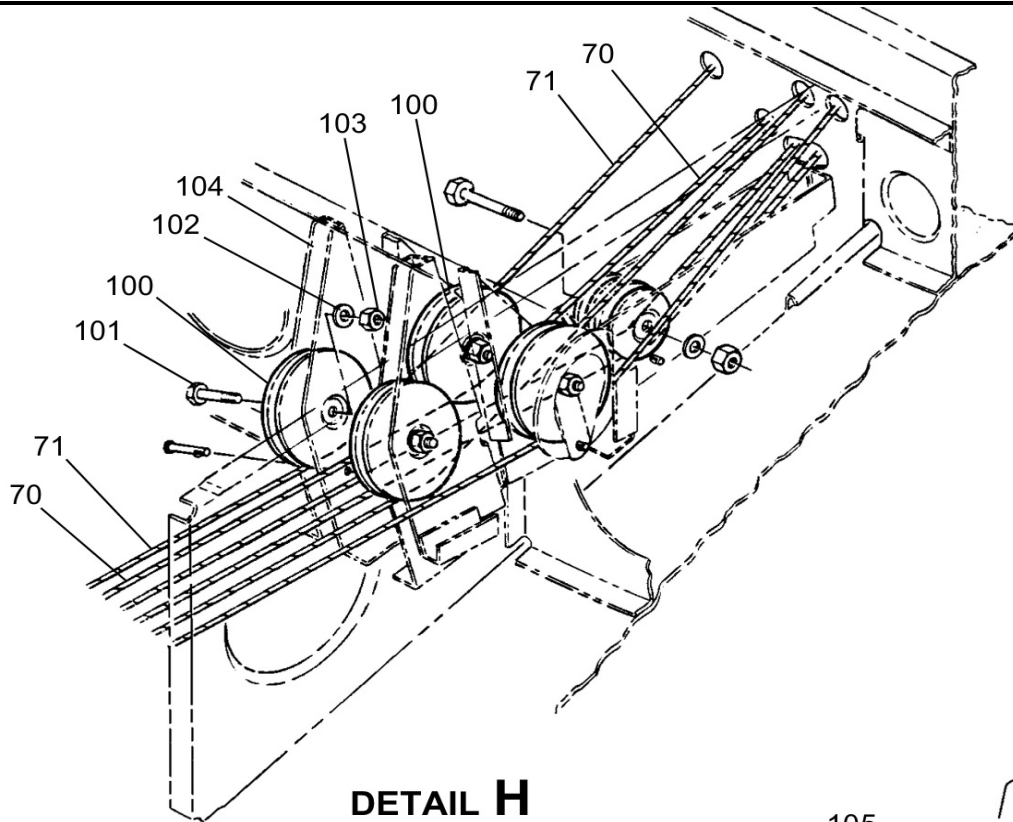
- 70. LEFT CABLE
- 71. RIGHT CABLE
- 90. FAIRLEAD SUPPORT
- 91. SUPPORT
- 92. BOLT
- 93. WASHER
- 94. NUT
- 95. PULLEY SUPPORT
- 96. SUPPORT
- 97. BOLT
- 98. WASHER

F26621001  
 G26631019

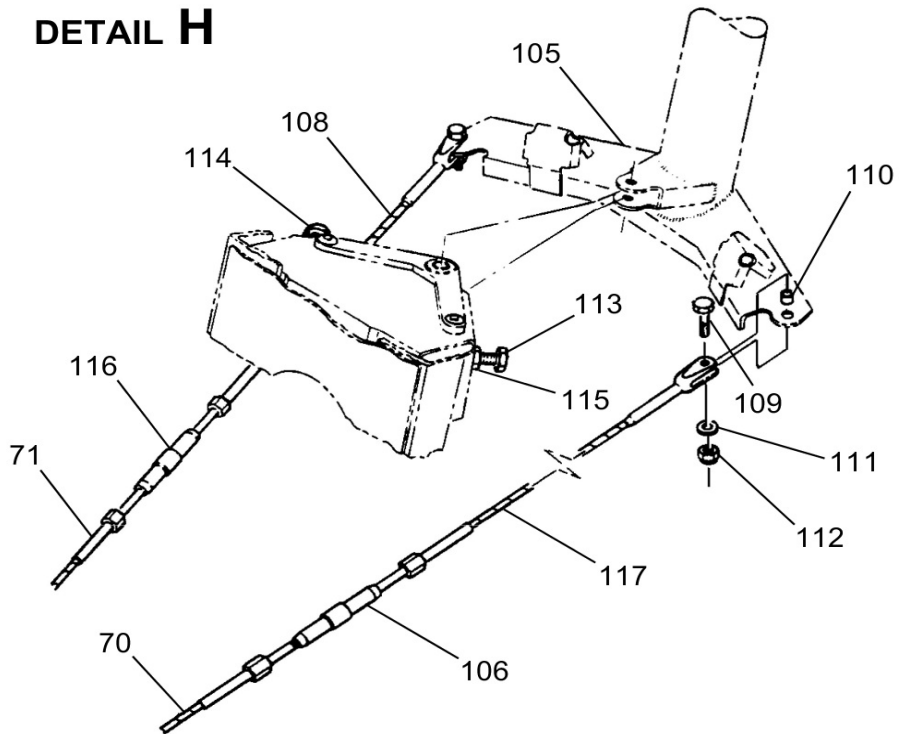


Figure 201 : Sheet 6 : Rudder System Installation

A22544



**DETAIL H**



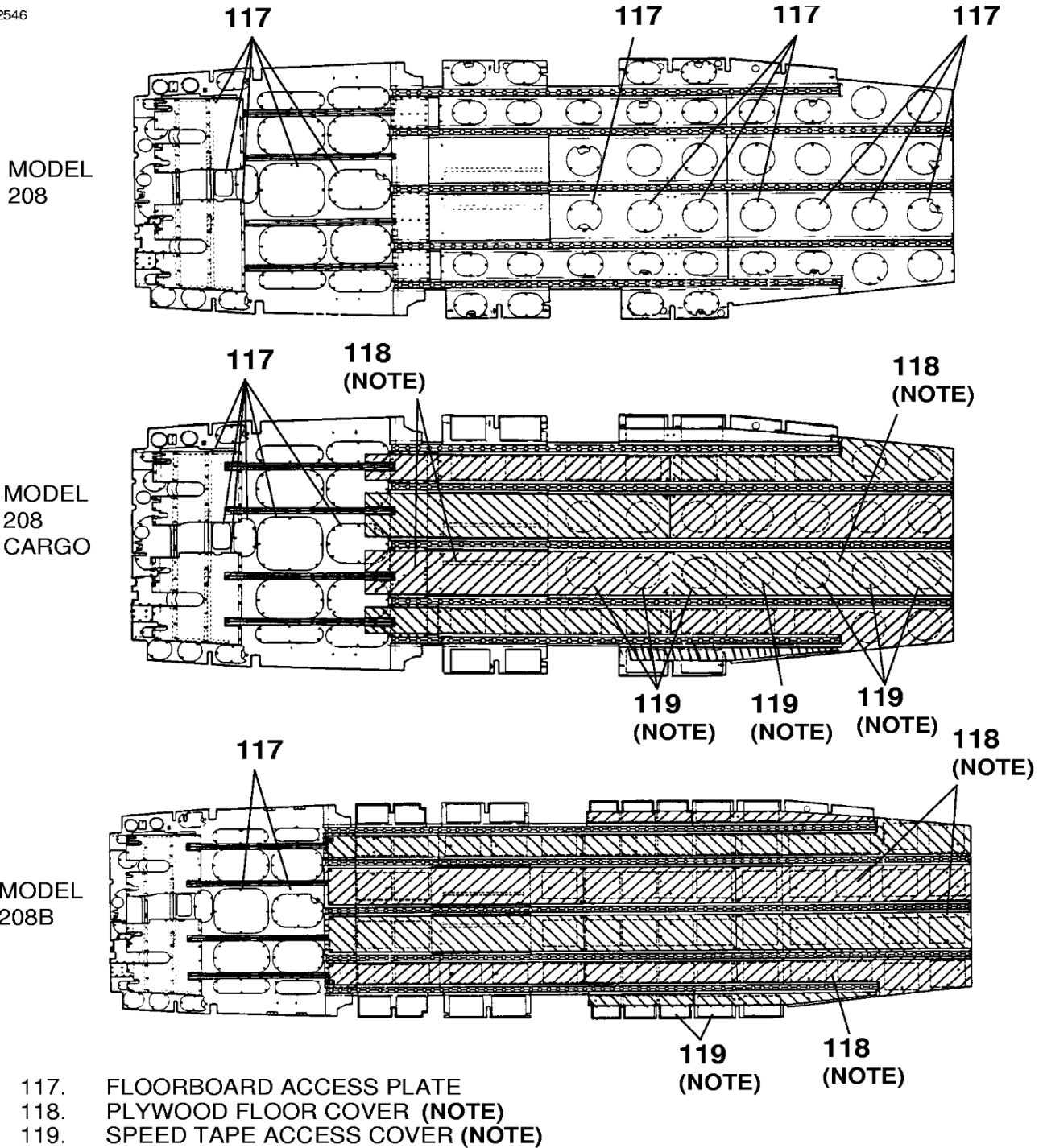
**DETAIL I**

- 70. LEFT CABLE
- 71. RIGHT CABLE
- 100. PULLEY
- 101. BOLT
- 102. WASHER
- 103. NUT
- 104. SUPPORT
- 105. RUDDER BELLCRANK
- 106. TURNBUCKLE
- 107. LEFT CABLE
- 108. RIGHT CABLE
- 109. BOLT
- 110. BUSHING
- 111. WASHER
- 112. NUT
- 113. LEFT STOP BOLT
- 114. RIGHT STOP BOLT
- 115. LOCKNUT
- 116. TURNBUCKLE

H2663R2011  
 I2662R1006

Figure 201 : Sheet 7 : Rudder System Installation

A22546



**NOTE:** REFER TO CHAPTER 53 FOR APPROPRIATE INSTRUCTIONS CONCERNING REMOVAL AND INSTALLATION OF PLYWOOD FLOOR COVERS AND SPEED TAPE ACCESS COVERS ON MODEL 208 AND 208B AIRPLANES.

26114003